

Drayton Lifestyle

SERVICE INTERVAL

SINGLE CHANNEL

Timeswitch

DUAL CHANNEL

Programmer

*for heating **OR** hot water*

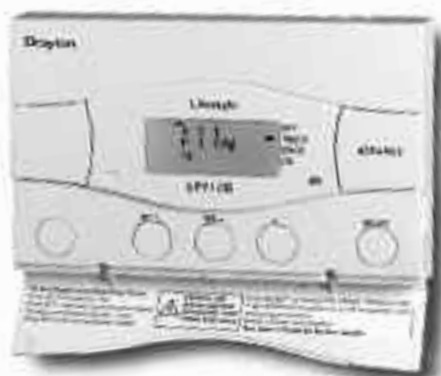

LP111Si, LP711Si

*for heating **AND** hot water*

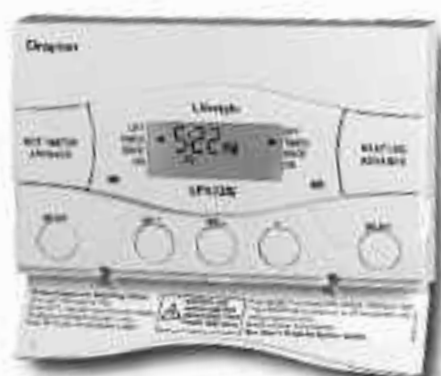

LP241Si, LP522Si, LP722Si

**SINGLE
CHANNEL**

**DUAL
CHANNEL**

Installation Instructions

06490050001 ISSC

Invensys Controls Europe

Sales: **0845 1305522** / Technical Helpline: **0845 1307722**

Email: customer.care@invensyscontrols.com / Web: www.draytoncontrols.co.uk

INSTALLATION INSTRUCTIONS

PLEASE NOTE: INSTALLATION MUST ONLY BE CARRIED OUT BY A QUALIFIED ELECTRICIAN OR HEATING ENGINEER.

MAKE SURE MAINS INPUT HAS A 3 AMP FUSE.

TECHNICAL DATA

LP241Si, LP522Si & LP722Si PROGRAMMERS LP111Si & LP711Si TIMESWITCHES	
Voltage	230V AC +10% - 10% 50Hz
Programmer Rating	2 (1) A 230V AC each switch
Timeswitch Rating	2 (1) A 230V AC
Ambient temp	Operating: 0° to 45°C Storage: -20°C to 50°C
Without mains power	Display: blank Time: always kept Program times: always preserved
Programming resolution	1 minute
Wiring	Fixed wiring only, to comply with current IEE regulations
Maintenance	Must be maintained by a qualified electrician or heating engineer

Lifestyle Programm器和 Timeswitches conform to the essential requirements of these Directives:

89/336/EEC – Electromagnetic compatibility

73/23/EEC – Low voltage



BEFORE INSTALLATION

First, make sure the mains supply is switched off!

PROGRAMMER ONLY

The programmer must be set to the type of system it is to control. The link on the back of the unit has two settings – P and G.

P = a fully pumped and controlled system – allowing heating and hot water to be set separately.

G = a gravity-fed hot water system – which does not allow independent setting of heating without hot water, though hot water can be controlled alone.

USING AN EXISTING WALL-PLATE

Loosen the securing screws on the old programmer and unplug it. Check that there's 70mm clearance to the right of the wall-plate, and 25mm above it. Check the chart on the next page to compare terminals and if necessary, change the wiring of the wall-plate to suit. Now plug the Lifestyle unit into the wall-plate and tighten the securing screws.

Check the 3A fuse, and switch on the mains.

FITTING A NEW WALL-PLATE

The ideal location is 1.4m above floor level, with reasonable lighting, good access, no condensation, no extremes of temperature, and a supporting surface that fully covers the back of the unit.

Position with 70mm clearance to the right, 25mm above, and sufficient room to access the securing screws underneath.

Fix, with terminals at the top, either direct to a flat wall using wall plugs and No. 6 x 1" (25mm) woodscrews, or on a flush mounting single conduit box type UA1 (BS4662) using M3.5 x 14 bolts. **DO NOT USE A SURFACE MOUNTING BOX.**

TIMESWITCH TERMINAL COMPARISONS

MAKE	MODEL	Earth	Neutral	Live	Common	On	Off	Spare
Current Models								
Drayton	Tempus 1, 2 (new models)		N	L	1	3	2	4
Lifestyle	LP111, LP711		N	L	1	3	2	4
Switchmaster	300		N	L	4	1		
Discontinued/Competitors' Models								
ACL	TC (Towerchron)		2	1	4	7		
Drayton	Tempus 1, 2 (old models)		N	L	1	2	3	4
Switchmaster	980		N	L	4	1		
Danfoss Randall	TS15, 75 (Mk18)	E	N	L	1	4	2	5/6
Danfoss Randall	TS715	E	N	L	1	4	2	3
Danfoss Randall	TS975	E	N	L	5	4	6	1,2,3
Danfoss Randall	SET1, SET1E	E	N	L	5	4	6	
Danfoss Randall	SET4	E	N	L	5	4	6	
Danfoss Randall	103, 103E, 103E5, 103E7	4	5	6	3	1		2
Danfoss Randall	911, 971	E	N	L	5	6	4	2
Grasslin Towerchron	QE1		N	L	2	4	3	
Grasslin Towerchron	T2001, T2001Q	E	N	L		7		
Honeywell	ST 6100A, ST 6100C		N	L	1	4	2	
Honeywell	ST 7000B			L		3	2	
Horstmann	Centaur SC1, SC7		N	L	4	3		
Horstmann	Centaur Plus, C11, C17		N	L	2	4	3	
Horstmann	Emerald 423, Pearl Auto	E	N	L	3	4		
Horstmann	517, Coronet, H11, H17	E	N	L	5	4	6	
Landis & Staefa	RWB3		N	L		4	3	
Landis & Staefa	RWB30, RWB50, 100, 152, 170		N	L	2	4	3	
Landis & Staefa	RWB7	N	L	2	4	3	1	
Potterton Myson	EP4000, 4001, 4002, 5002		N	L	5	4	2	
Sangamo	M6	E	4	6	3	1	2	
Smiths	Centroller Mk1, Mk2		N	L	3	2		
Smiths	Centroller 30		1	2		4/5		
Smiths	Centroller 300, 980		N	L	4	1		
Sunvic	Select 107		N	L	1	3	2	4
Sunvic	SP20, SP35		N	L	3	5	4	S
Venner	Vennerette		N	L	LINE	LOAD		

PROGRAMMER TERMINAL COMPARISONS

MAKE	MODEL	Earth	Neutral	Live	H/W off	C/H off	H/W on	C/H on
Current Models								
Drayton	Tempus 6, 7 (new models)		N	L	1	2	3	4
Lifestyle	LP112, LP241, LP522, LP722		N	L	1	2	3	4
Switchmaster	400, 600 (no connection to terminal 4 on 600)		N	L		4	3	1
Switchmaster	805		N	L	4	2	3	1
Discontinued/Competitors' Models								
ACL	MP (Towerchron)		2	1			6	10
ACL	FP (Towerchron)		2	1	8	11	6	10
Drayton	Tempus 3, 4, 6, 7 (old models)		N	L	1	2	3	4
Switchmaster	905, 9001		N	L	4	2	3	1
Danfoss Randall	CP15, CP715, FP15, FP715 (Mk18)	E	N	L	1	2	3	4
Danfoss Randall	3020P, 3060	E	7	6			4	2
Danfoss Randall	4033 (link 1-6)	E	7	6	5	3	4	2
Danfoss Randall	102, 102E, 102E5, 102E7 (link 6-3)	E	5	6			1	2
Danfoss Randall	701 (link L-5 and 5-6)	E	N	L			3	1
Danfoss Randall	702 (link L-5 and 5-6)	E	N	L	4	2	3	1
Danfoss Randall	922, 972 (link L-2 and 2-5)	E	N	L	1	4	3	6
Danfoss Randall	SET2, SET2E, SET3E, SET3M, FP975 SET5 (link L-2 and 2-5)	E	N	L	3	6	1	4
Grasslin Towerchron	DP 72, QE2		N	L	1	2	3	4
Honeywell	ST 699/799 (link L-5 and 5-8)		N	L	7	4	6	3
Honeywell	ST 6200, ST 6300, ST 6400, ST 6450		N	L	1	2	3	4
Honeywell	ST 7100 (link L-3 and 3-6)		N	L	7	4	8	5
Horstmann	525, 527, 425 Diadem, H21, H27, H121, Tiara (link L-2 and 2-5)	E	N	L	3	6	1	4
Horstmann	Centaur Plus, C21, C27		N	L	1	2	3	4
Landis & Staefa*	RWB2, RWB2E, 20, 40, 102, 200, 252 & 270, RWB9		N	L	1	2	3	4
Myson	Microtimer (link L-5 and 5-8)		N	L	7	4	6	3
Potterton Myson	All EP2000's, EP3000's, EP6000's (link L-5 and N-N)		N	L	1	2	3	4
Potterton Myson*	Mini Minder		N	L	1	2	3	4
Sunvic	Select 207		N	L	1	2	3	4
Sunvic	SP50, SP100 (link L-3)		N	L	1	4	2	5

WIRING THE TIMESWITCH

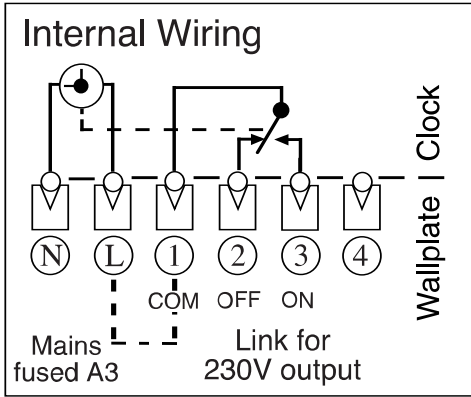

Make the wiring connections as above. Note that the output contacts are voltage-free, so power needs to be put on to Terminal 1 either by linking from Terminal L or from a separate supply with a 3A fuse.

WIRING THE PROGRAMMER

USING A DRAYTON SIMP-L-FIT, ALTHOUGH NOT NECESSARY, WILL MAKE THIS INSTALLATION EASIER.

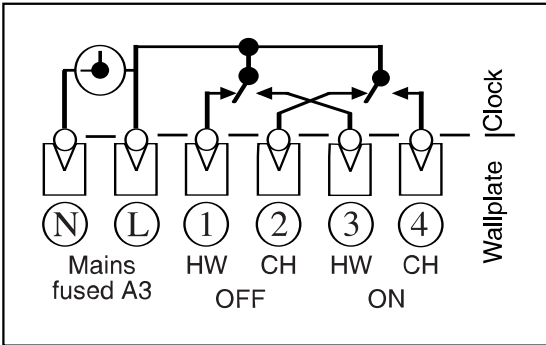

Connection Charts

Arrowed numbers relate to the junction box.

Consult boiler handbook for details of pump overrun wiring.

***Thermostat Key**

- C Common
- H Call for Heat
- S Satisfied
- N Neutral
- E Earth
- L Live

Wiring Colour Codes

- GR Grey
- Y Yellow
- BK Black
- BL Blue
- BR Brown
- RD Red
- W White
- OR Orange
- YG Yellow/Green

Connection Charts

ROOM THERMOSTAT Gravity HW, Pumped CH with Room Stats

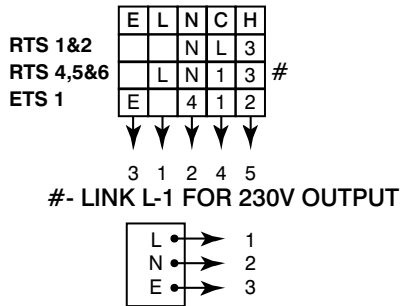

Switched and Fused
(3A) Mains input

† For pump overrun boilers consult manufacturer's instructions

* See Thermostat Key

PROGRAMMER

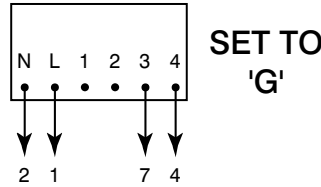

PUMP

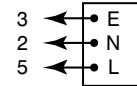

JUNCTION BOX

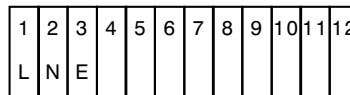

LWC3

BOILER

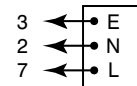

Mid-Position Valve System

ROOM THERMOSTAT

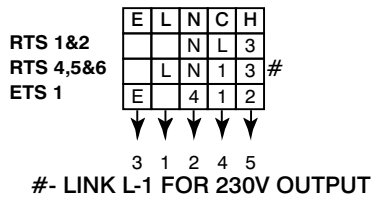

Switched and Fused
(3A) Mains input

† For pump overrun boilers consult manufacturer's instructions

* See Thermostat Key

PROGRAMMER

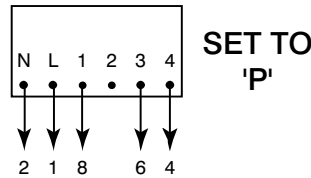

CYLINDER THERMOSTAT

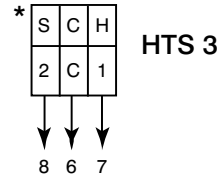

JUNCTION BOX



LWC3

PUMP

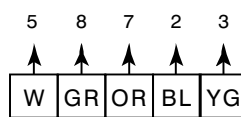
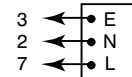

MID-POSITION VALVE

LIFESTYLE 679H340-30L0 (22mm)
LIFESTYLE 779H340-30L0 (28mm)
DRAYTON FLOWSHARE 2

Honeywell
V4073A
Landis & Gyr
MAV 3

BOILER

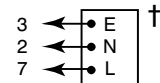

Spring-Return 2-Valve System

ROOM THERMOSTAT

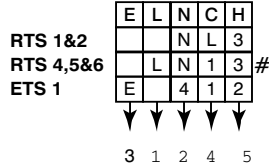

#- LINK L-1 FOR 230V OUTPUT

PROGRAMMER

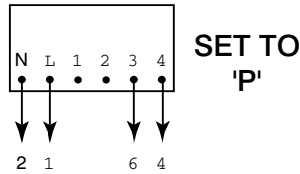

CYLINDER THERMOSTAT

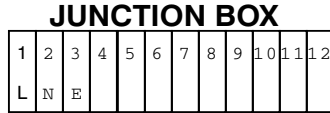
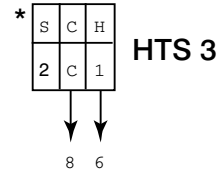

LWC3

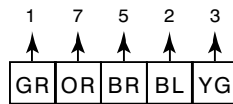
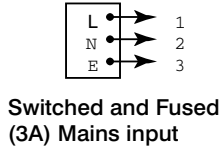

CH VALVE

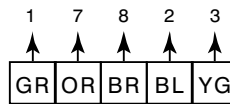

DHW VALVE

LIFESTYLE 679H308-30L1
LIFESTYLE 779H33530L10
DRAYTON ZV22

Honeywell
V4043H1056
Landis & Gyr
ZAV222

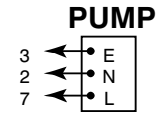

PUMP

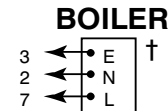

BOILER

† For pump overrun boilers consult manufacturer's instructions

* See Thermostat Key

Make the wiring connections, as above, for the appropriate system.

For surface wiring, snap out the cable entry strip on the bottom edge of the wall-plate. Lifestyle units are double-insulated and need no earth connection, but an earthing continuity (loop) terminal is provided for convenience.

After wiring, plug in the unit and tighten the securing screws. Check the mains input has a 3A fuse, and switch on the mains. Then set the timings as shown in the User's Guide.

ALWAYS SWITCH OFF THE MAINS BEFORE REMOVING THE LIFESTYLE TIMESWITCH/PROGRAMMER - AND NEVER FIT IT TO A LIVE WALL-PLATE!

SERVICE INTERNAL FEATURE

Applicable to all models.

If you wish to activate, or adjust, the settings for the 'service interval' feature then please refer to the instructions for the service interval (LP Si) reset module [SOLD SEPARATELY]

INSTALLERS/ENGINEERS NOTES

Invensys Controls Europe

Sales: 0845 1305522 / Technical Helpline: 0845 1307722
Email: customer.care@invensyscontrols.com / Web: www.draytoncontrols.co.uk